

Gap 1 = 7mm

7.00 mm

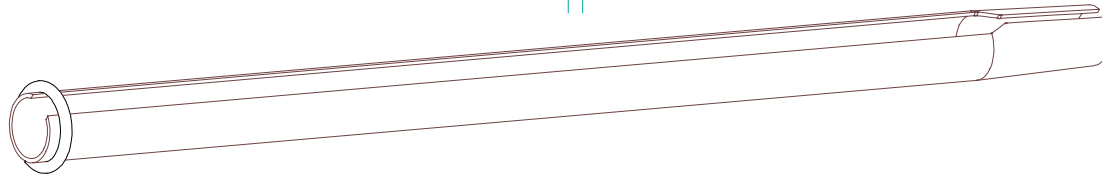
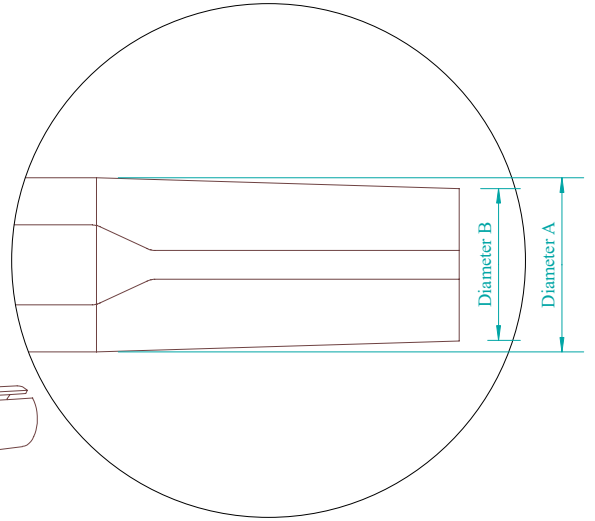
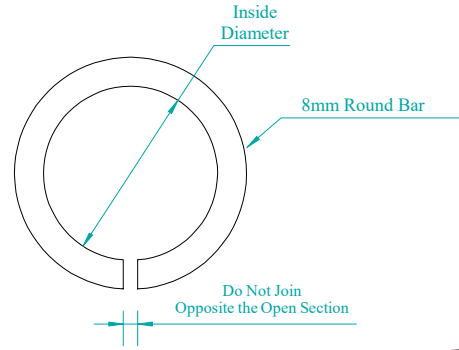
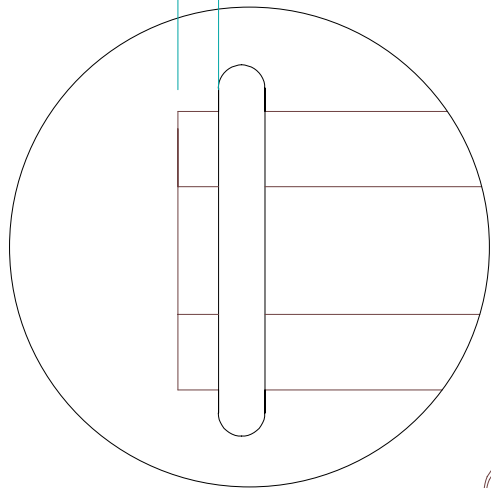

7.00 ± 1 mm

Gap 2 = 45.00mm

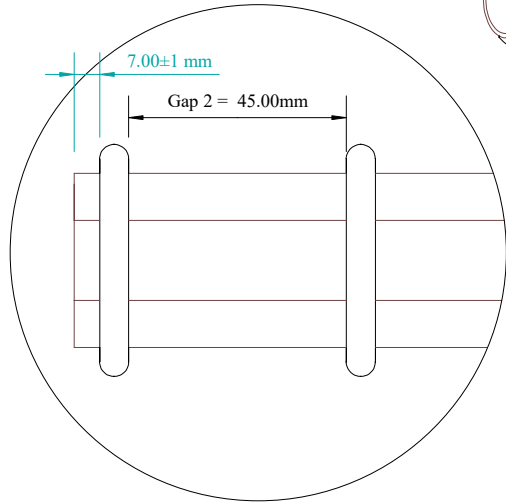

Split set Diameter	Ring Inside Diameter	S/S Length ± 5 mm	Split Set Diameter B	Material Thickness	Gap No 1 ± 2 mm	Gap No 2 ± 2 mm
33.00 mm	33.00 mm	900mm	28.00mm ± 1.5 mm	2.30 mm	7.00mm ± 2 mm	45.00mm ± 2 mm
39.00 mm	39.00 mm	900mm	36.00mm ± 1.5 mm	2.30 mm	7.00mm ± 2 mm	45.00mm ± 2 mm
46.00 mm	46.00mm	2,400mm	42.00 mm ± 1.5 mm	3.20 mm	7.00mm ± 2 mm	45.00mm ± 2 mm

Notes: Straightness - 1.50 mm per 1 Meter
 Twist - 2.00mm per 1 Meter
 Test - 10% : Pull Test

Material : S 420 Mc Black, Zinc or Galvanised
 or:
 3CR 12 Stainless Steel

Approval
 Customer

UG
 UGMINING PTY LTD
 6A OSLO RD
 PRETORA
 R.S.A

Title : 33.00mm - 46.00mm Open Split Section
 Friction Bolt

Rev:

Insp. Auth.

Drawn:

Date:

Scale: 1:1

Drg No: